

IN LINE FILTERS

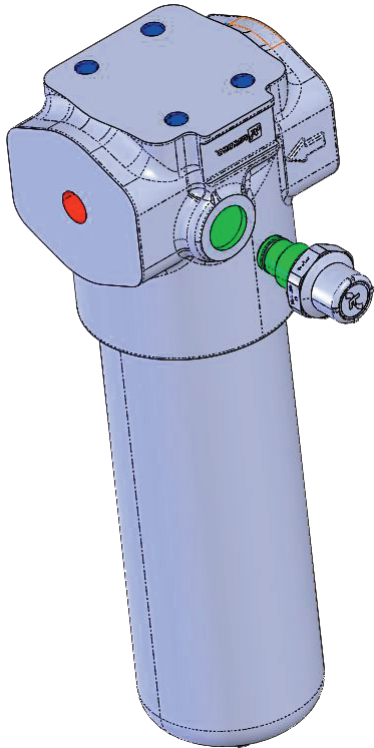

- **BLU** - threaded holes for fixing the filter housing on the frame of the system or machine.
- **RED** - IN-OUT connection ports (indicate the center hole only, as it can be of various sizes).
- **GREEN** - indicator port. The model of the indicator or of the plug has the thread of the same colour.

RETURN FILTERS

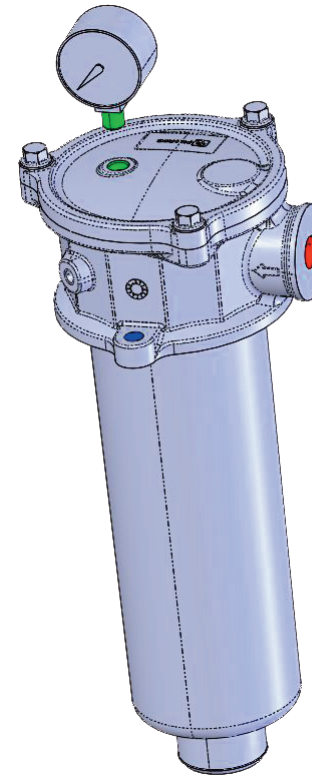

- **BLU** - clearance holes for fixing the filter housing on the oil tank lid.
- **RED** - IN connection port. (indicate the center hole only, as it can be of various sizes).
- **GREEN** - indicator port. The model of the indicator or of the plug has the thread of the same colour.