



FUHF50 SERIES

Transfer and Filtration Portable Unit for Diesel and Oil.

Designed for superior performance, it offers dual filtration to remove water and solid contaminants, ensuring your oil and diesel remains clean and efficient.



TECHNICAL SPECIFICATION

MAIN:	Flow Rate: 50 l/min Operating temperature: from -10 °C to +50°C Fluid viscosity: Diesel from 2 to 5,35 cSt Oil from 4,5 to 300 cSt (500 cSt short term)
ELECTRIC:	Voltage: 220 V Frequency: 50 - 60 Hz Power consumption: 1,6 kW
FRAME:	Dimensions L, W, H[mm]: 581X546X1160
MATERIALS:	Base frame: Painted

ELEMENT

	tested according to ISO 11170, 2941, 2942, 2943, 3724, 3968, 16889, 16908, 23181
FILTER MEDIA:	Fiberglass: G01 - G03 - G06 - G10 - G25 Water absorbent: GW40 - AW40
FLUID COMPATIBILITY:	Full With HH-HL-HM-HV-HETG-HEES (acc. to ISO 6743/4). Diesel EN590. ASTM D975 Biodiesel B0 to B100 EN14214 Fuel oil EN51603-1 For use with other fluid please contact Filtrac Customer Service (info@filtrac.it).

The unit is supplied complete with an Instruction and Maintenance Manual available on our website www.filtrac.com in the "Hydraulic Filter" section. The unit can be used by authorized operators who have read and understood all of its contents.

The FUHF50 filtration unit is certified **CE**

OVERALL DIMENSIONS

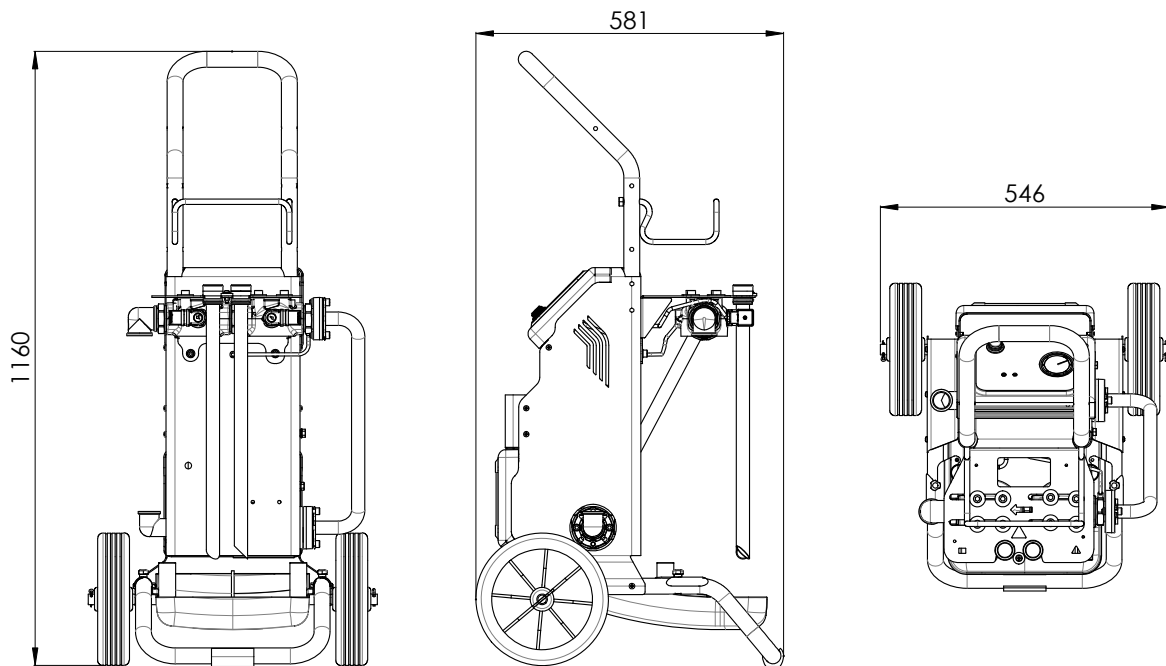

HYDRAULIC DIAGRAM

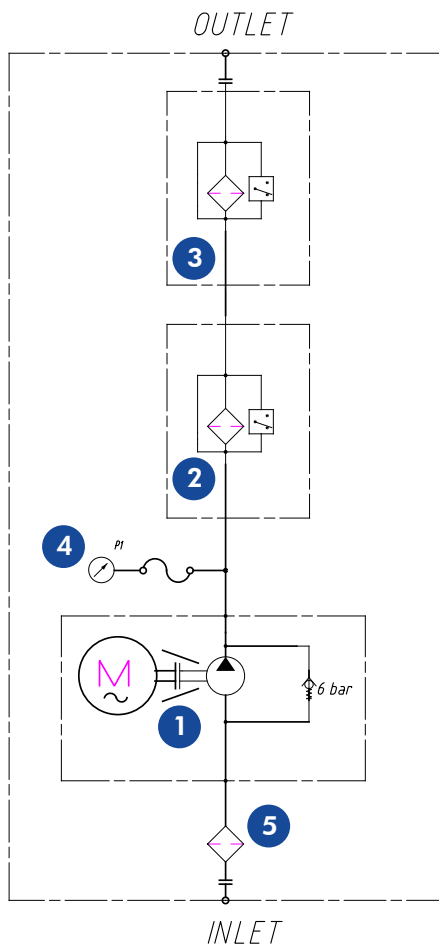

- | | |
|---|--|
| 1 | Vane Pump 1,6 kW + pressure relief valve 6 bar |
| 2 | Particle removal filter |
| 3 | Water absorbent filter |
| 4 | Pressure Gauge |
| 5 | Foot Valve |

ORDERING INFORMATION

FUHF50

1.	2.	3.	4.	5.	6.	7.	8.
FUHF	50	M	G	2	V	S	0

1. FILTER UNIT SERIES	FUHF	
2. MODEL	50	flow rate 50 l/min
3. ELECTRIC MOTOR	M	Single phase electric motor, 230V 50-60Hz 1,6 kW
4. PUMP SIZE	G	Vane pump suitable for Oil and diesel fuel (internal pressure relief valve @6 bar)
5. FILTER / ELEMENT SIZE	2	2 x A522.../AB2 series
6. SEAL	V	FKM
7. VERSION	S	standard version
8. OPTION	0	<ul style="list-style-type: none"> - with n.2 clogging indicator model VEXF2 differential visual electric 2,7 bar for filter - support frame with removal drip tray - foot valve (ON /OFF) with suction strainer - suction and delivery pipes + lances L=3 - 2P+T type "F" plug (Schuko),L= 5m - control panel with ON/OFF switch - control panel with indicator lights for: SYSTEM ON CLOGGED FILTER #1* & #2* <p>*= it does not turn off the system, filter #1 for solid contaminants, filter #2 water absorbent</p>

ACCESSORIES

The accessories must be ordered separately

06.022.00003 Nozzle



ORDERING INFORMATION

SPARE PARTS FOR MAINTENANCE

06.022.00001	Replacement vane kit for vane pump
06.022.00002	Foot valve (manual ON/OFF) with suction strainer

ORDERING INFORMATION SPARE ELEMENTS

1.	2.	3.	4.	5.	6.
A5	22	G01	V	0	/AB2
1. FILTER ELEMENT SERIES	A5				
2. FILTER SIZE	22				
3. FILTER MEDIA	G01	glassfiber $\beta_{4\mu m(c)} \geq 10.000$ Anti ESD -AbsoluteBeta Sparkbuster technology included			Filter #1 specific for Diesel Fuel
	G03	glassfiber $\beta_{5\mu m(c)} \geq 5.000$ Anti ESD -AbsoluteBeta Sparkbuster technology included			
	G06	glassfiber $\beta_{7\mu m(c)} \geq 2.000$			Filter #1 specific for Hydraulic Oil
	G10	glassfiber $\beta_{10\mu m(c)} \geq 2.000$			
	G25	glassfiber $\beta_{25\mu m(c)} \geq 2.000$			
	GW40	glassfiber $\beta_{35\mu m(c)} \geq 1.000$ + water absorbent			only for Filter #2
	AW40	water absorbent only (higher water retention capacity)			
	4. SEAL	V	FKM		
5. BYPASS VALVE	0	no bypass			
6. ELEMENT SUFFIX	/AB2	AbsoluteBeta 2 - very high capacity / efficiency filter element			

 FILTER ELEMENT - Preferred filter media - For the complete range of elements available, refer to the FA5 series catalog.

USER TIPS

The filter element must be replaced when:

1. Either the clogging indicator of the particle removal filter or the water absorbent filter shows a clog, or if both clogging indicators show a clog, or if the pressure gauge reaches 5 bar.
2. A different filter medium is required. We recommend using a fine filtration medium for the particle removal filter and a water absorbent filter for water removal.

The unit is supplied complete with an Operating Manual available on our website www.filtrec.com in the "Hydraulic Filter" section. The unit can be used by authorized operators who have read and understood all of its contents.

WHY A CLEAN AND FREE OF WATER FUEL IS IMPORTANT

In the last 20 years the requirements of emissions regulations for internal combustion engines became every year more stringent.

To achieve the emissions target, manufacturers use high pressure injection systems on their diesel engines. Today, almost all the diesel engines use a High Pressure Common Rail (HPCR) system to inject the fuel, with pressure up to 2500 bar.

Due to the high pressure and the tight tolerances of these systems, the cleanliness of the fuel and its water content is very important.

In fact, solid contamination leads to wear and erosion of the different components of the injection system, while water leads to corrosion, reduced fuel efficiency and injector damage.

For the above reasons, it is vital to use clean and dry fuel in your diesel engines.

Examples of solid contamination in diesel fuel – ISO 4406 cleanliness level

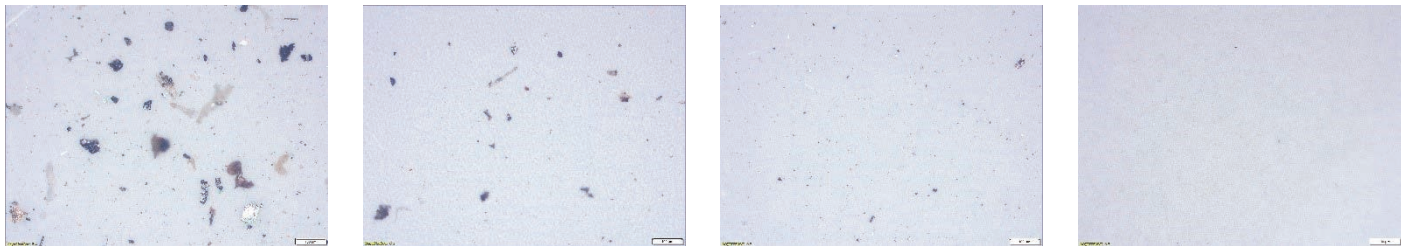

Cleanliness target for diesel fuel in last generation engine: between 16/14/12 and 13/11/9 according to ISO 4406

FILTREC FUHF50 DIESEL FILTRATION UNIT

With Filtrec FUHF50 Series Diesel Filtration Unit you can remove solid contamination and water from the fuel during the filling of the tank of your machines.

This unit features a 50 l/min vane pump and 2 different filters: one to stop the solid particle contamination and the other to absorb the water present in the fuel.

The particle removal filter has a high efficiency, glass fiber media, with a β ratio at $4 \mu\text{m}(c)$ up to 10000 (G01 media). This filter is able to remove the particle contamination in a single-pass filtration.

The water removal filter element is specifically designed for the absorption of water from diesel fuel.

This water absorption technology configuration is an efficient method to remove water contamination.

The water absorbing filter media, embedded in the filter material, removes water by a physical-chemical reaction.

When absorbed, the water particles are locked physically by the gel formed and are not able to return to the fluid.

This reaction is not reversible also with increased pressure.

However, diesel fuel passes through this media without interference.

When the gel formation is complete, the media stops the water removal reaction.

In this way you are sure to avoid any problems related to the solid contamination and water in the fuel.

