



DOX1012 SERIES

Duplex Pressure Filter according to API614 latest edition.

In line filters for operating pressure up to 40 bar flow rate up to 70 l/min.



HOUSING

PRESSURE:	Max operating: 40 bar
TEMPERATURE:	Max operating: 100°C
CONNECTIONS:	1" SAE 3000 1" Ansi 150 RF 1" Ansi 300 RF DN25 PN16 DN25 PN40
MATERIALS:	Head: St.Steel 316/316L Body: St.Steel 316/316L Seal: NBR (FKM option) 3-Way valve: Steel 316/316L

ELEMENT

	tested according to ISO 11170, 2941, 2942, 2943, 3724, 3968, 16889, 16908, 23181
FILTER MEDIA:	Fibreglass: G03 - G05 - G10 G15 - G20 - G40 Synthetic Media: M05 - M08 - M10 - M15 Wire Mesh: T25 - T40 - T80 - T125
COLLAPSE PRESSURE:	20 bar
TEMPERATURE RANGE:	with NBR seal from -30 °C to +100 °C with FKM seal (OPTION) from -25 °C to +120 °C with EPDM seal (ON REQUEST) from -57 °C to +150 °C with HNBR seal (ON REQUEST) from -48 °C to +150 °C

OVERALL DIMENSIONS

IN/OUT 1" SAE 3000

VENT/DRAIN 1/2" NPT-F

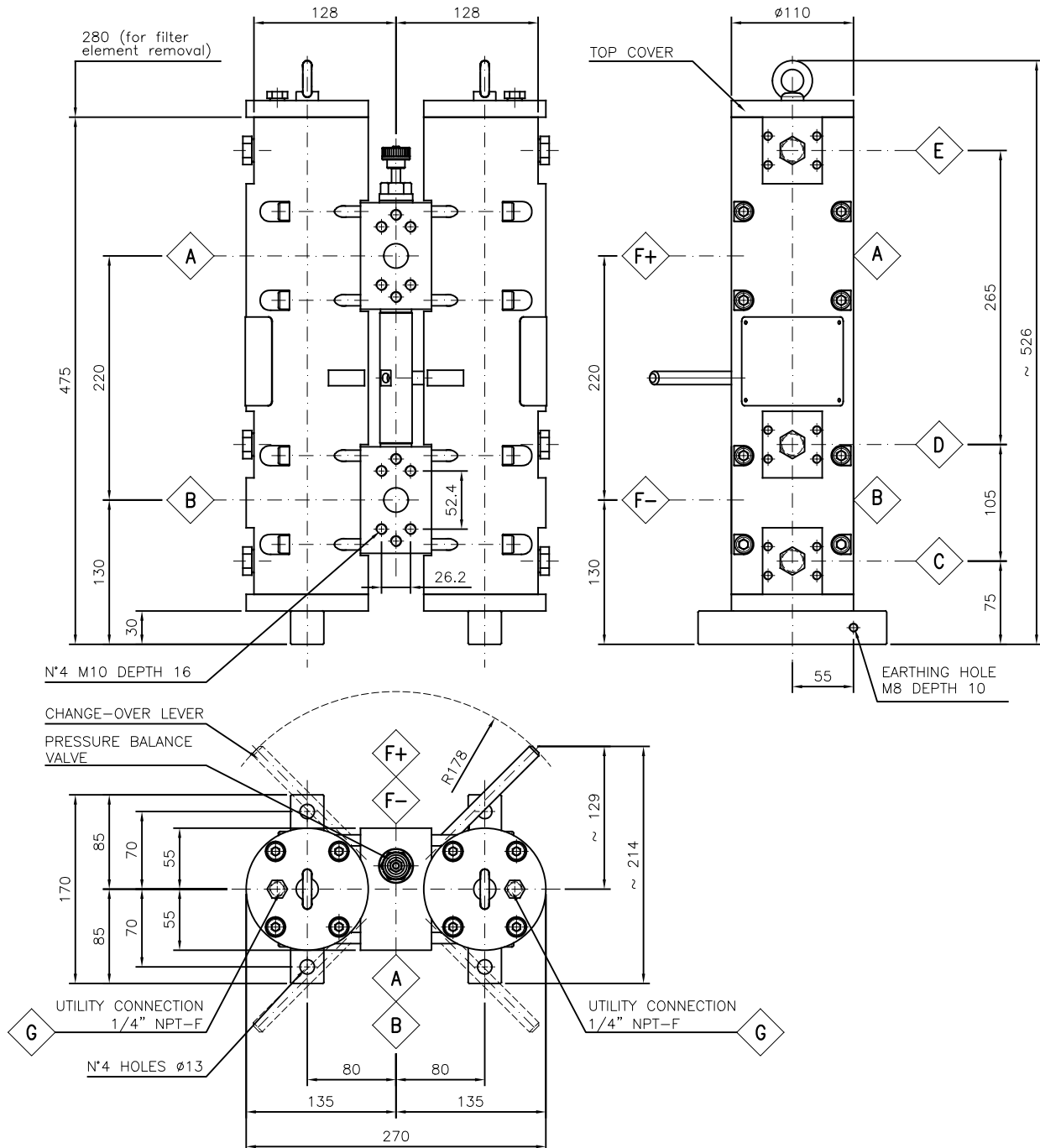

OVERALL DIMENSIONS

IN/OUT 1" ANSI150/300 PN16/PN40

VENT/DRAIN 1/2" NPT-F

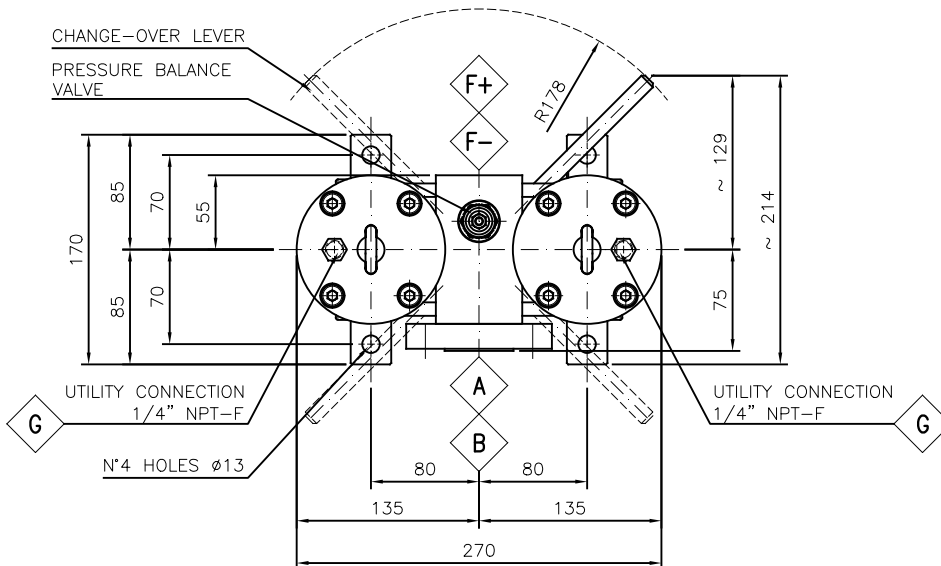
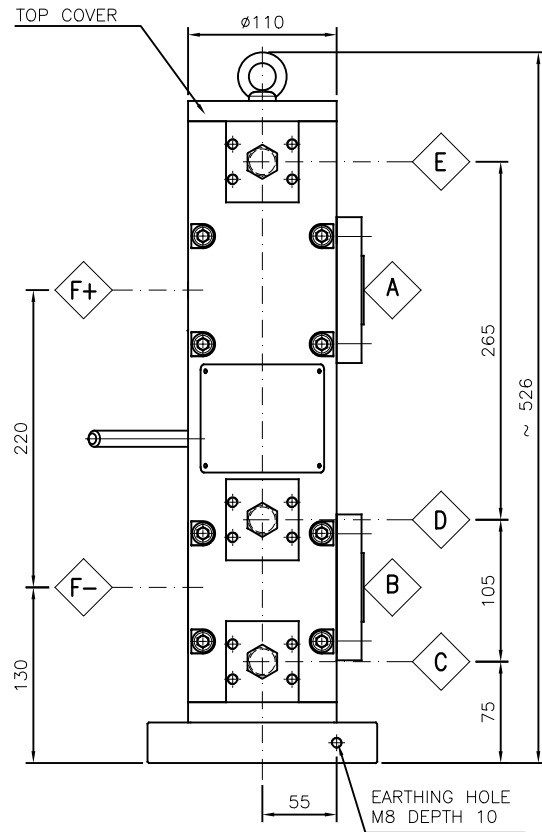
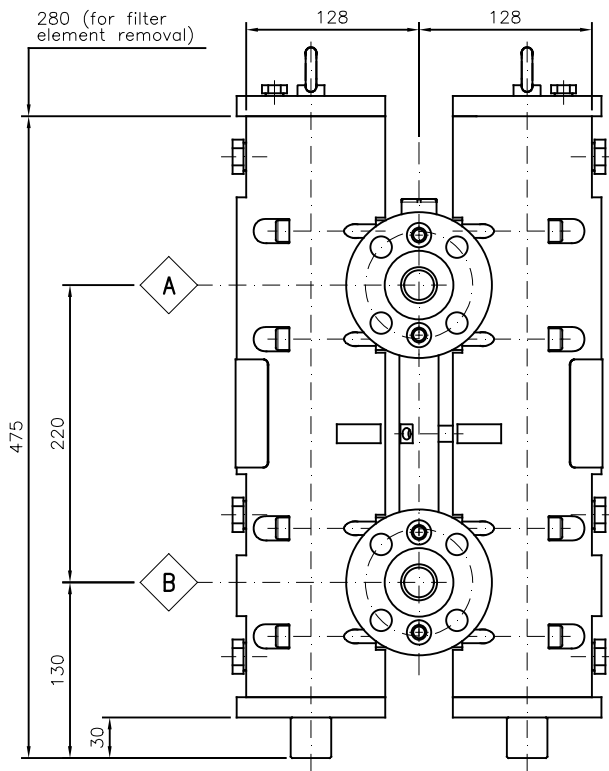

OVERALL DIMENSIONS

DUPLEX FILTER WITH VENT AND DRAIN FLANGED CONNESSION

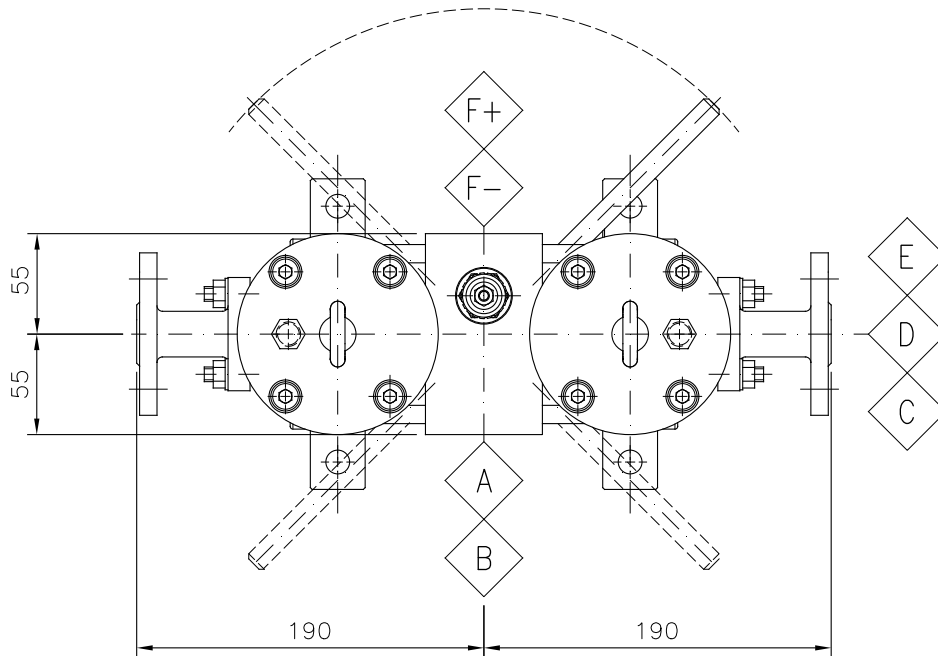

LEVER POSITION FOR DUPLEX FILTER WITH DIFFERENTIAL INDICATOR

DIFFERENTIAL VISUAL
or ELETRICAL INDICATOR

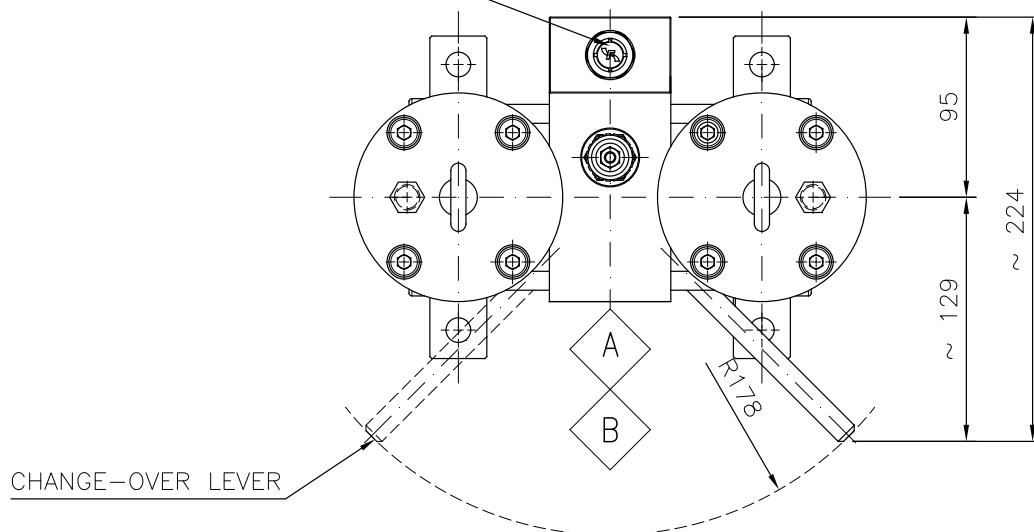

ORDERING INFORMATION

1.	2.	3.	4.	5.	6.	7.	8.	9.	10.	11.	12.	13.
DOX	S	B	1012	S	025	A	A	0	G15	ESD	000	-0000

1. FILTER SERIES	DOX	
2. MATERIAL	S	Stainless Steel 316/316L
3. SEALS	B	NBR
	V	FKM (option)
	E	EPDM (on request)
	H	HNBR (on request)
4. HOUSING SIZE	1012	
5. PORT TYPE	A	Ansi 150 flange
	B	Ansi 300 flange
	P	PN16 flange
	R	PN40 flange
	S	SAE 3000 (max working pressure 16 bar)
	T	SAE 3000 (max working pressure 40 bar)
6. PORT SIZE	025	1" DN25
7. VENT and DRAIN	A	1/2" NPT-F
	B	1/2" Ansi 150 flange
	C	DN15 PN16 flange
	D	1/2" Ansi 300 flange
	E	DN15 PN40 flange
8. DESIGN CODE	A	ASME VIII div.1
	B	ASME VIII div.1, U-STAMP
	C	ASME VIII div.1, U-STAMP, NBR
	D	EN13445-3
9. AREA CLASSIFICATIONS	0	Safe Area
	1	ATEX II 2G Ex h IIC T4 Gb (*)
10. FILTER MEDIA	G03	Glassfiber $\beta_{5\mu\text{m}(c)} \geq 1.000$
	G05	Glassfiber $\beta_{7\mu\text{m}(c)} \geq 1.000$
	G10	Glassfiber $\beta_{12\mu\text{m}(c)} \geq 1.000$
	G15	Glassfiber $\beta_{17\mu\text{m}(c)} \geq 1.000$
	G20	Glassfiber $\beta_{22\mu\text{m}(c)} \geq 1.000$
	G40	Glassfiber $\beta_{35\mu\text{m}(c)} \geq 1.000$
	M05	Synthetic $\beta_{10\mu\text{m}(c)} \geq 1.000$
	M08	Synthetic $\beta_{12\mu\text{m}(c)} \geq 1.000$
	M10	Synthetic $\beta_{15\mu\text{m}(c)} \geq 1.000$
	M15	Synthetic $\beta_{20\mu\text{m}(c)} \geq 1.000$
	T25	Wire mesh 25 μm
	T40	Wire mesh 40 μm
	T80	Wire mesh 80 μm
	T125	Wire mesh 125 μm

(*) Ambient temperature -40°C ÷ +50°C
Max operating temperature fluid +85°C

ORDERING INFORMATION

11. ELEMENT VERSION	ESD	Anti-static technology
	002	Stainless Steel end caps and metal parts
12. CLOGGING INDICATOR Differential pressure indicator block and fittings are included. (Y) digit for FKM seal option (**) Available only for safe area	000	No indicator
	VX1 (VY1)	Differential visual set 1,3 bar
	VX2 (VY2)	Differential visual set 2,7 bar
	VX5 (VY5)	Differential visual set 5 bar
	EX1 (EY1)	Differential electrical set 1,3 bar (**)
	EX2 (EY2)	Differential electrical set 2,7 bar (**)
	EX5 (EY5)	Differential electrical set 5 bar (**)
13. VERSION	-0000	Identification numbers assigned by FILTREC after order

DOX1012 SERIES MAIN FEATURES

Stainless steel weld-free construction.

Continuous-flow transfer valve: double 3 ways ball valve, full bore type, zero leak with anti-static device.

Filter element made with anti-static technology, to prevent electrostatic discharge.

Beta rated elements according to ISO 16889 multipass test.

Certification of materials EN10204 type 3.1

For different seal materials, filtration degree, media and certification please contact Filtrac Customer Service.

PRESSURE DROP (Δp) INFORMATION FOR FILTER SIZING

The total Δp through a filter assembly is given from Housing Δp + Element Δp .

N.B. All the reported data have been obtained at our laboratory, according to specification ISO3968 with mineral oil having 32 cSt viscosity and density 0,875 Kg/dm³.

HOUSING PRESSURE DROP

The housing Δp is given by the curve of the considered model and port, in correspondence of the flow rate value.

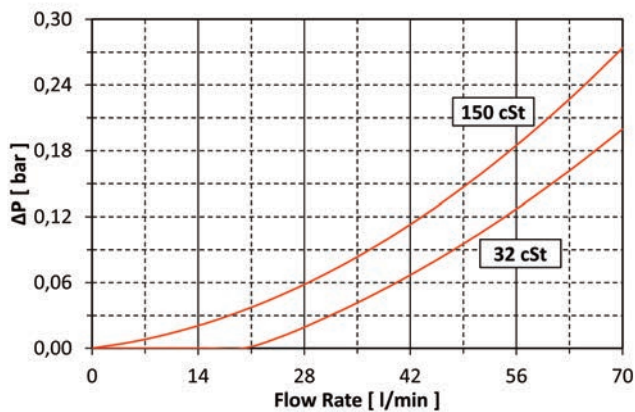

ELEMENT PRESSURE DROP (filter elements 20 bar collapse)

The element Δp (bar) is given by the flow rate (l/min) multiplied by the factor in the table here below corresponding to the selected media and divided by 1000.

If the oil has a viscosity V_x different than 32 cSt a corrective factor $V_x/32$ must be applied.

50 l/min with OX1012G15B0/ESD and oil viscosity 46 cSt: $(50 \times 2,23 / 1000) \times (46 / 32) = 0.16$ bar

	G03	G05	G10	G15	G20	G40	M05	M08	M10	M15	T25	T40	T80	T125
OX1012....0/...	6.84	4.05	2.89	2.23	2.00	0.74	1.70	1.53	1.35	1.08	0.28	0.26	0.25	0.21

EXAMPLE OF TOTAL Δp CALCULATION

DOXSB1012S025AA0G150-0000 with 50 l/min and oil 46 cSt:

Housing Δp + element $\Delta p = 0.1$ bar + $(50 \times 2.23 / 1000) \times (46 / 32)$ bar = 0.26 bar

USER TIPS

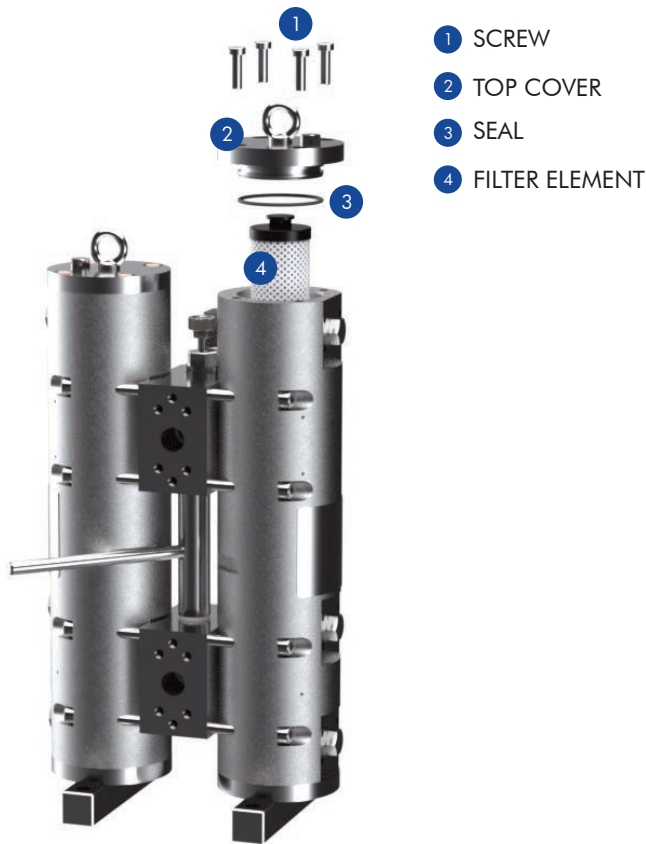

SPARE SEAL KIT PART NUMBER

	NBR	FKM
TOP COVER SEAL KIT	10.011.00066 (Kit of 2 cover gaskets)	10.011.00067 (Kit of 2 cover gaskets)



WARNING

-  Make sure that Personal Protective Equipment (PPE) is worn during installation and maintenance operation.

DISPOSAL OF FILTER ELEMENT

-  The used filter elements and the filter parts dirty of oil are classified as "Dangerous waste material": they must be disposed according to the local laws by authorized Companies.

INSTALLATION

-  1. Secure the frame of the filter using the fixing holes.
- 2. The IN and OUT ports must be connected to the hoses in the correct flow direction.
- 3. Verify that no tension is present on the filter after mounting.
- 4. Enough space must be available for filter element replacement.
- 5. The visual clogging indicator must be in a easily viewable position.
- 6. When a electrical indicator is used, make sure that it is properly wired.
-  7. Never run the system with no filter element fitted.
- 8. Keep in stock a spare FILTREC filter element for timely replacement when required.
- 9. Filter housing should be earthed.

OPERATION

-  1. The filter must work within the operating conditions of pressure, temperature and compatibility given in the first page of this data sheet.
- 2. The filter element must be replaced as soon as the clogging indicator signals at working temperature (in cold start conditions, oil temperature lower than 30°C, a false alarm can be given due to oil viscosity).
- 3. If no clogging indicator is mounted, replace the element according to the system manufacturer's recommendations.

