



FLRD-U5 SERIES

In line medium pressure filters

In line filters for operating pressure up to 16 bar.
Flow rate up to 1600 l/min.



HOUSING	tested according to NFPA T3.10.5.1, ISO 10771, ISO 3968
PRESSURE:	Max operating: 16 bar
CONNECTIONS:	DN80 + 3" SAE 3000 FLANGE-M DN100 + 4" SAE 3000 FLANGE-M
MATERIALS:	Head: anodized aluminium Bowl: anodized aluminium Body: anticorodal aluminium Seal: NBR (FKM on request) Manifold Welded: Carbon steel 3-Way valve: Steel Check valve: Cast steel
BYPASS VALVE:	no bypass 1 bar 3 bar 4 bar 6 bar
ELEMENT	tested according to ISO 11170, 2941, 2942, 2943, 3724, 3968, 16889, 16908, 23181
FILTER MEDIA:	Fibreglass: G01 - G03 - G06 - G10 G15 - G25 - G40 - GW03 - GW10 AW40
COLLAPSE PRESSURE:	10 bar
TEMPERATURE RANGE:	with NBR seal from -30 °C to +100 °C with FKM seal (OPTION) from -25 °C to +120 °C
FLUID COMPATIBILITY:	Full with HH-HL-HM-HV HETG-HEES (acc. to ISO 6743/4). For use with other fluid please contact Filtrec Customer Service (info@filtrec.it).

OVERALL DIMENSIONS

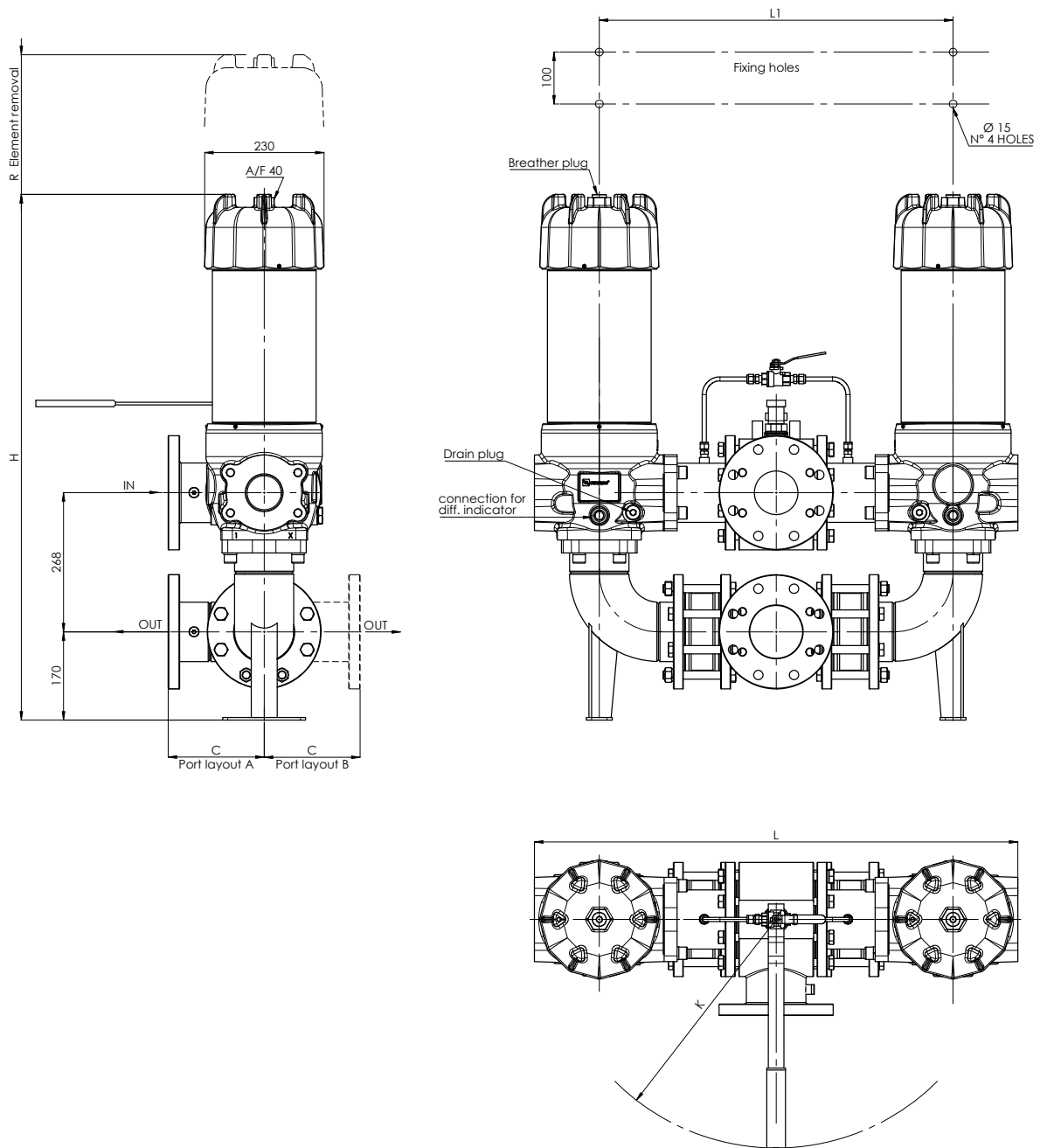

NOMINAL SIZE

XX	MODEL	PORTS LAYOUT	PORT SIZE (IN - OUT)	L	L1	C	K	R	H	BODY WEIGHT
F10M	FLRD-U5-62	A	DN80 + 3" SAE 3000 FLANGE-M	870	588	175	380	460	1065	138 Kg
F12M			DN100 + 4" SAE 3000 FLANGE-M	932	682	185	440			166 Kg
F10M		B	DN80 + 3" SAE 3000 FLANGE-M	870	588	175	380	900	1503	138 Kg
F12M			DN100 + 4" SAE 3000 FLANGE-M	932	682	185	440			166 Kg
F10M	FLRD-U5-64	A	DN80 + 3" SAE 3000 FLANGE-M	870	588	175	380	900	1503	157 Kg
F12M			DN100 + 4" SAE 3000 FLANGE-M	932	682	185	440			185 Kg
F10M		B	DN80 + 3" SAE 3000 FLANGE-M	870	588	175	380	900	1503	157 Kg
F12M			DN100 + 4" SAE 3000 FLANGE-M	932	682	185	440			185 Kg

ORDERING INFORMATION

	1.	2.	3.	4.	5.	6.	7.	8.	9.	10.	11.	12.
	FLRD	U5	64	G10	B	0	F12M	A	1	000	S	0
SPARE ELEMENT	U5	64	G10	B	0							

1. FILTER SERIES	FLRD	
2. FILTER ELEMENT SERIES	U5	
3. FILTER SIZE	62	
	64	
4. FILTER MEDIA	000	no element
	G01	glassfiber $\beta_{4\mu m(c)} \geq 1.000$
	G03	glassfiber $\beta_{5\mu m(c)} \geq 1.000$
	G06	glassfiber $\beta_{7\mu m(c)} \geq 1.000$
	G10	glassfiber $\beta_{12\mu m(c)} \geq 1.000$
	G15	glassfiber $\beta_{17\mu m(c)} \geq 1.000$
	G25	glassfiber $\beta_{22\mu m(c)} \geq 1.000$
	G40	glassfiber $\beta_{35\mu m(c)} \geq 1.000$
	GW03	glassfiber $\beta_{5\mu m(c)} \geq 1.000$ + water absorbent
	GW10	glassfiber $\beta_{12\mu m(c)} \geq 1.000$ + water absorbent
5. SEALS	B	NBR
	V	FKM
6. BYPASS VALVE	0	no bypass
	1	1 bar
	3	3 bar
	4	4 bar
	6	6 bar
7. MAIN PORT	F10M	MAIN INLET AND OUTLET DN80 + 3" SAE 3000 FLANGE (METRIC SCREWS)
	F12M	MAIN INLET AND OUTLET DN100 + 4" SAE 3000 FLANGE (METRIC SCREWS)
8. PORTS LAYOUT	A	front: inlet and outlet on the same side
	B	in line: inlet and outlet on the opposite side
9. INDICATOR PORT OPTION	1	indicator seat on both sides: left metal plug, right plastic cap
	2	indicator seat on both sides with metal plug
	3	indicator seat on both sides with plastic plug
10. COMPULSORY FIELD	000	filtrec standard
11. CORROSION PROTECTION	S	painted piping and valve + anodized filters
12. OPTION	0	no option
	1	internal tube for low flow rate 150-200 LPM

ORDERING INFORMATION

ACCESSORIES

The accessories must be ordered separately

INDICATOR

(Y and F) digit for FKM seal option

*LC24=Led connector

For other options see clogging indicators catalogue

VX2 (VY2)	differential visual 2,7bar	
EX2 (EY2)	differential electric 2,7bar	
EX2L (EY2L)	differential electric 2,7bar + LC24*	
VEXF2	differential visual and electric 2,7 bar	
VX5 (VY5)	differential visual 5bar	
EX5 (EY5)	differential electric 5bar	
EX5L (EY5L)	differential electric 5bar + LC24*	
VEXF5	differential visual and electric 5bar	
VX8 (VY8)	differential visual 8bar	
EX8 (EY8)	differential electric 8bar	recommended for no by-pass option
EX8L (EY8L)	differential electric 8bar + LC24*	
VEXF8	differential visual and electric 8 bar	
LC24	LED connector for pressure switch	

PLUG

P01	metal plug for indicator port - NBR
PF1	metal plug for indicator port - FKM

HYDRAULIC SYMBOLS

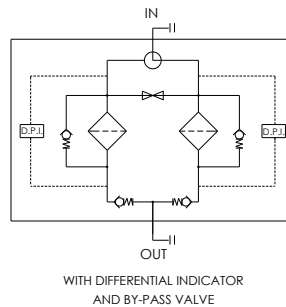
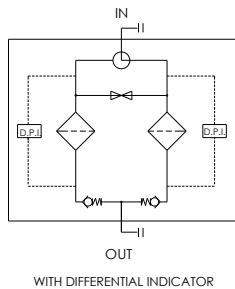

PRESSURE DROP (Δp) INFORMATION FOR FILTER SIZING

The total Delta P through a filter assembly is given from Housing Δp + Element Δp .

This ideally should not exceed 1.0 bar and should never exceed 1/3 of the set value of the by-pass valve. N.B. All the reported data have been obtained at our laboratory, according to specification ISO3968 with mineral oil having 32 cSt viscosity and density 0.875 Kg/dm³.

HOUSING PRESSURE DROP

The housing Δp is given by the curve of the considered model and port, in correspondence of the flow rate value.

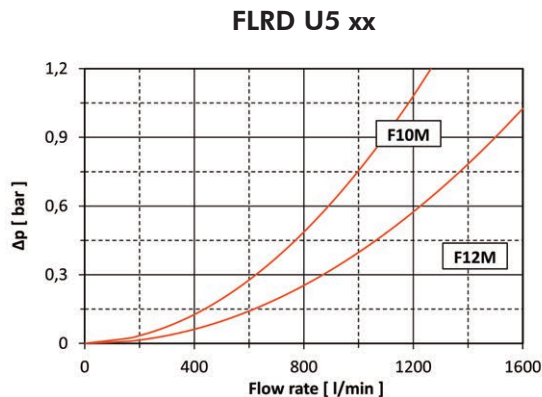

ELEMENT PRESSURE DROP

The element Δp (bar) is given by the flow rate (l/min) multiplied by the factor in the table here below corresponding to the selected media and divided by 1000.

If the oil has a viscosity V_x different than 32 cSt a corrective factor $V_x/32$ must be applied.

1000 l/min with U564G10B0 and oil viscosity 46 cSt: $(1000 \times 0.09 / 1000) \times (46 / 32) = 0.13$ bar

	G01	G03	G06	G10	G15	G25	G40	GW03	GW10	AW40
U562	0.97	0.40	0.32	0.19	0.17	0.11	0.07	1.15	0.55	0.22
U564	0.45	0.19	0.15	0.09	0.08	0.06	0.03	0.58	0.28	0.11

EXAMPLE OF TOTAL Δp CALCULATION

FLRDU564G10B0F12MA1000S0 with 1000 l/min and oil 46 cSt:

Housing Δp + element Δp = 0.40 bar + $(1000 \times 0.09 / 1000) \times (46 / 32)$ bar = 0.53 bar

GW03, GW10 AND AW40 QUICK SIZE TABLE

	suggested flow rate [l/min]	GW03 and GW10 water capacity* [l]	AW40 water capacity* [l]
U562	75	1.31	1.50
U564	152	2.65	3.03

* at final $\Delta p = 3$ bar

BYPASS VALVE PRESSURE DROP

The bypass valve Δp is given by the curve of the considered model and setting, in correspondence of the flow rate value.

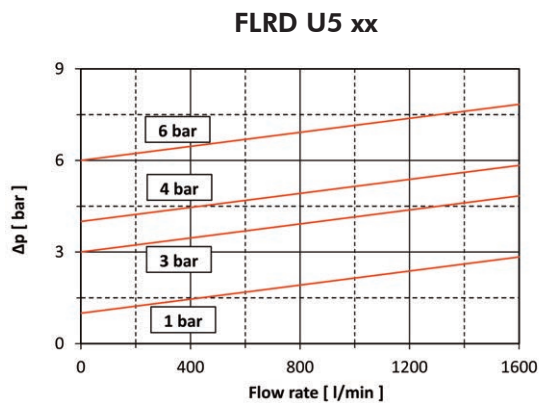

N.B. All the reported data have been obtained at our laboratory, according to specification ISO3968 with mineral oil having 32 cSt viscosity and density 0.875 Kg/dm³.

USER TIPS

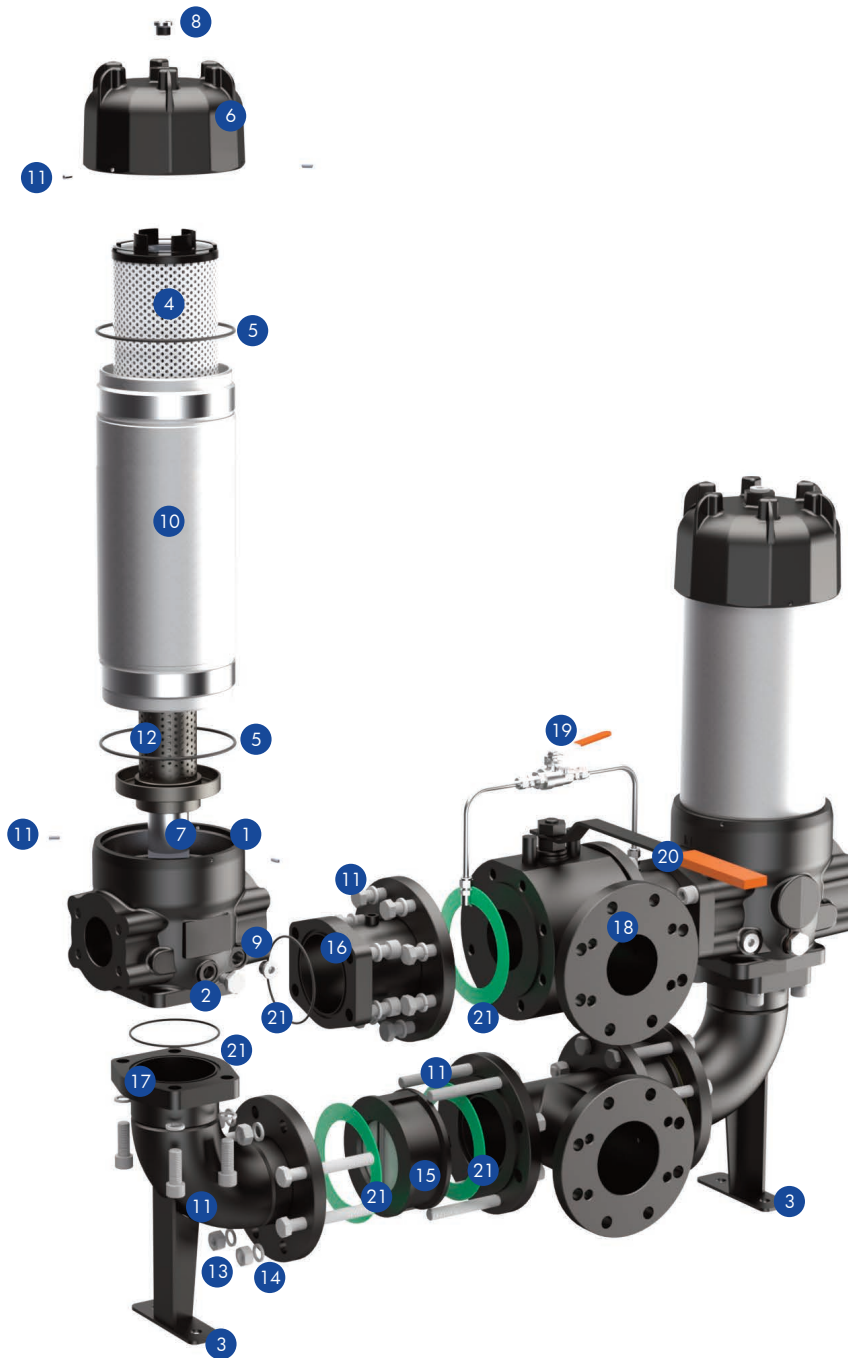

- 1 FILTER HEAD
- 2 INDICATOR PORT
- 3 FIXING HOLES
- 4 FILTER ELEMENT
- 5 SEAL KIT FILTERS
- 6 FILTER BOWL
- 7 INTERNAL TUBE FOR LOW FLOW RATE
- 8 VENT PLUG
- 9 DRAIN PLUG
- 10 FILTER BODY
- 11 FIXING SCREWS
- 12 SUPPORT TUBE
- 13 NUT
- 14 WASHER
- 15 CHECK VALVE
- 16 FLANGE ASSEMBLY
- 17 FITTING ASSEMBLY
- 18 VALVE
- 19 PRESSURE EQUALIZING
- 20 SWITCHING LEVER
- 21 SEAL KIT PIPINGS

SPARE SEAL KIT PART NUMBER

	NBR	FKM
FLRD...F10... (21) (3" SAE / DN 80)	06.021.00407	06.021.00408
FLRD...F12... (21) (4" SAE / DN 100)	06.021.00409	06.021.00410
FLR... (5)	06.021.00389	06.021.00390

BOWL/BODY TIGHTENING TORQUE

screw up filter bowl/body till end

INDICATOR/DRAIN/VENT TIGHTENING TORQUE

50 Nm



WARNING

-  Make sure that Personal Protective Equipment (PPE) is worn during installation and maintenance operation.

DISPOSAL OF FILTER ELEMENT

-  The used filter elements and the filter parts dirty of oil are classified as "Dangerous waste material": they must be disposed according to the local laws by authorized Companies.



INSTALLATION

-  1. Secure the frame of the filter using the fixing holes (3).
- 2. The IN and OUT ports must be connected to the hoses in the correct flow direction.
- 3. Verify that no tension is present on the filter after mounting.
- 4. Enough space must be available for filter element replacement.
- 5. The visual clogging indicator must be in a easily viewable position.
- 6. When a electrical indicator is used, make sure that it is properly wired.
-  7. Never run the system with no filter element fitted.
- 8. Keep in stock a spare FILTREC filter element for timely replacement when required.
- 9. Filter housing should be earthed.

OPERATION

-  1. The filter must work within the operating conditions of pressure, temperature and compatibility given in the first page of this data sheet.
- 2. The filter element must be replaced as soon as the clogging indicator signals at working temperature (in cold start conditions, oil temperature lower than 30°C, a false alarm can be given due to oil viscosity).
- 3. If no clogging indicator is mounted, replace the element according to the system manufacturer's recommendations.

MAINTENANCE

-  1. Operate and hold pressure equalizing (19) lever located behind switching lever. Pull catch knob and swivel switching lever (20).
- 2. Loosen vent screw (8).
- 3. Remove drain plug (9) in housing bottom and drain oil.
- 4. Unscrew the 3 grub screws (11) of the filter bowl (6).
- 5. Unscrew filter bowl counter-clockwise.
- 6. Lift out filter element (4).
- 7. Check seal on filter bowl (5). We recommend replacement in any case.
- 8. Make sure that the order number on the spare element corresponds to the order number of the filter name-plate. To ensure no contamination occurs during the exchange of the element, first open the plastic bag, then push the element over the spigot in the filter head. Now remove plastic bag.
- 9. Push the element carefully over the spigot, mount the filter bowl (6) and tighten the 3 grub screws (11).
-  10. Tighten drain plug (9) in housing bottom.
- 11. To refill the filter chamber, operate only the pressure equalizing lever, until fluid emerges bubble-free from the vent cavity.
- 12. Tight vent screw. Check for leakage by actuating the equalizing lever again.
- 13. The used filter elements can not be cleaned and re-use.

