



Operating Manual FMSS01S0

MOISTURE AND TEMPERATURE SENSOR



Read the safety and operating instructions
prior to commissioning!

Note: Representations do not always exactly correspond to the original. No legal claims arise from information provided by us in error. Technical information may change without notice.

| | | |
|------------|--|----|
| 1. | Quick Start | 3 |
| 2. | Performance and measurement principles | 4 |
| 2.1 | General..... | 4 |
| 2.2 | Temperature measurement..... | 4 |
| 2.3 | Humidity measurement..... | 4 |
| 2.3.1 | Relative humidity..... | 4 |
| 2.4 | Operating hours counter..... | 4 |
| 3. | Technical specifications | 5 |
| 3.1 | General data..... | 5 |
| 3.2 | Dimensions..... | 5 |
| 4. | Mounting | 6 |
| 5. | Electrical connection | 7 |
| 5.1 | Sensor Pin assignment..... | 7 |
| 5.2 | Analog current outputs (4..20 mA) - measurement without load resistance..... | 7 |
| 5.3 | Analog current outputs (4..20 mA) - measurement with load resistance..... | 8 |
| 5.3.1 | Load resistance..... | 8 |
| 6. | Communication | 9 |
| 6.1 | Serial interface (RS232)..... | 9 |
| 6.1.1 | Interface parameters..... | 9 |
| 6.2 | Command list..... | 9 |
| 6.2.1 | Read Command..... | 9 |
| 6.2.2 | Write commands..... | 9 |
| 6.2.3 | Setting the analog current outputs..... | 10 |
| 6.3 | FMSS01S0 Sensor Software..... | 10 |
| 7.1 | Function test using a PC..... | 13 |
| 7.2 | Function test via the analog current outputs..... | 13 |
| 8. | Reference Values | 13 |
| 9. | Maintenance and disposal | 13 |
| 10. | Troubleshooting | 14 |
| 11. | Accessories | 15 |

1. Quick Start

The following section describes the steps for initial commissioning of the Moisture Sensor FMSS01S0 to be carried out at the PC. For this purpose, the following components are required:

1. PC / Laptop with RS232 connection, or alternatively with a USB port, which serves as a measuring computer
2. Moisture Sensor FMSS01S0 (order number: 04.006.00188)
3. Sensor cable FMSA04S0 (order number: 04.006.00191)
4. Power supply incl. cold device plug FMSA01S0 (order number: 04.006.00190)
5. FMSS01S0 Sensor Software (this can be downloaded from www.filtrec.com)
6. In addition, when connected via USB: USB-RS232 converter FMSA05S0 (order number: 04.006.00194)

The components are to be prepared as follows:

- A) Software Installation
 1. No Installation is required. Just copy the file "FMSS01S0_Sensor_Software.exe" to your PC. The Windows operating systems are supported.
- B) Software installation of the driver for the USB-RS232 converter with data acquisition via USB (If you do not use a converter, please continue with point D)
 2. Now connect your USB-RS232 converter to your PC / laptop.
 3. If the USB-RS232 converter is not known by the PC, the corresponding driver must be installed.
- C) Sensor connection with data acquisition via USB
 4. Connect the sensor cable to the M12 connector at the sensor.
 5. Connect the 9-pin D-Sub connector of the cable to the appropriate serial port of the USB-RS232 converter.
 6. Connect the power supply and the sensor cable.
 7. Now properly connect your power supply via the cold device plug to the mains voltage. Your sensor is now ready for operation.
- D) Sensor connection with data acquisition via RS232
 8. Connect the sensor cable to the M12 connector at the sensor.
 9. Connect the 9-pin D-Sub connector of the cable to the appropriate serial port of your PC / laptop.
 10. Connect the power supply and the sensor cable.
 11. Now properly connect your power supply via the cold device plug to the mains voltage. Your sensor is now ready for operation.
- E) Starting the software
 12. The Software can be started by double click on the file "FMSS01S0_Sensor_Software.exe"

The following list describes the main methods used to wire the sensor and the parts needed:

- 1) Sensor to USB port
 - a. code FMSA01S0, P/N 04.006.00190, universal power supply
 - b. code FMSA04S0, P/N 04.006.00191, data cable for computer connection
 - c. code FMSA05S0, P/N 04.006.00194, adapter USB - RS232 serial
- 2) Sensor to RS232 port
 - a. code FMSA01S0, P/N 04.006.00190, universal power supply
 - b. code FMSA04S0, P/N 04.006.00191, data cable for computer connection
- 3) Sensor to open ends
 - a. code FMSA03S0, P/N 04.006.00192, data cable with open ends

For a complete list and description of all the available accessories please refer to section 11 of this manual.

2. Performance and measurement principles

2.1 General

The FMSS01S0 Moisture Sensor serves to measure changes in the properties of hydraulic and lubricating media. The corresponding measured values are continuously recorded and can be issued via a serial interface or via two 4..20 mA current outputs.

The sensor detects the following two physical characteristics

- temperature
- relative humidity

2.2 Temperature measurement

For measuring the oil temperature, a PT1000 platinum resistance sensor is used. The measuring range extends from -20 °C to +120 °C. Since the resistance sensor is directly in the oil, the conductivity of the surrounding medium may not exceed a value of 3 mS/m.

2.3 Humidity measurement

The measurement of relative humidity ϕ is effected by using a capacitive transducer. The capacitive humidity sensor detects the relative humidity in the range between 0% and 100%. In case of free water or emulsions, the sensor indicates 100%.

2.3.1 Relative humidity

Relative humidity ϕ is understood to be the ratio of the actually in the oil contained (ρ_w) to the maximum possible amount of dissolved water at the saturation limit ($\rho_{w,max}$).

$$\phi = \frac{\rho_w}{\rho_{w,max}} \cdot 100 \quad (2-1)$$

Since the saturation limit, i.e. the maximum absorbable absolute humidity $\rho_{w,max}$, is strongly temperature dependent, the relative humidity varies with the temperature, even when the absolute humidity remains constant. Usually, oils absorb more water with increasing temperature.

2.4 Operating hours counter

The sensor has an operating hours integrated counter whose values are still present even after power failure. After interruption, the counter restarts counting at the last recorded (stored) value before the interruption.

3. Technical specifications

3.1 General data

| Sensor Data | Size | Unit |
|--|---|-------------------------------|
| Max Operating Pressure | 50 | bar |
| Operating conditions Temperature ¹ Relative humidity ¹ | -20 ... 120 0 ... 100 | °C % r.H. (non-condensing) |
| Compatible liquids | mineral oils (H, HH, HL, HM, HV, HLP, HLPD, HVLP) synthetic esters (HETG, HEPG, HEES, HEPR) polyalkyleneglycols (PAG) zinc and ash-free oils (ZAF) polyalphaolefins (PAO) | |
| Wetted Materials | aluminum, HNBR, polyurethane resin, epoxy resin, chemical nickel / gold (ENIG), soldering tin (Sn60Pb40, Sn96,5Ag3Cu0,5NiGe), aluminum oxide, glass (DuPont QQ550) | |
| Protection class ² | IP67 | |
| Power supply ³ | 9 ... 33 | V |
| Current consumption | Max. 60 | mA |
| Output Current output (2x) ⁴ Accuracy current output ⁵ Interfaces | 4...20 ±2 RS232 | mA % - |
| Connecting dimensions Threaded connection Tightening torque connection thread Electrical connection Tightening torque M12 connector | G $\frac{3}{4}$ 45 ±4,5 M12x1, 8-pole 0,1 | Inch Nm - Nm |
| Measuring range Rel. humidity Temperature | 0...100 -20...120 | % r.H. °C |
| Measuring resolution Rel. humidity Temperature | 1 0,1 | % r.H. K |
| Measuring accuracy ⁶ Rel. humidity (10...90 %) ⁷ Rel. humidity (<10 %, >90 %) ⁷ Temperature | ±3 ±5 ±2 | % r.H. % r.H. K |
| Response time humidity measurement (0 to 100 %) | <1 | min |
| Weight | 115 | g |

¹ Outside the specified measuring range, there are possibly no plausible measuring values to be expected

² With screwed on connector

³ Automatic switch off at U <8 V and U >36 V, with load-dump impulses over 50V an external protection must be provided

⁴ Outputs IOut1 and IOut2 are freely configurable (see operating manual)

⁵ In relation to the analogue current signal (4 ... 20 mA)

⁶ Works calibration

⁷ Calibrated to air at room temperature

3.2 Dimensions

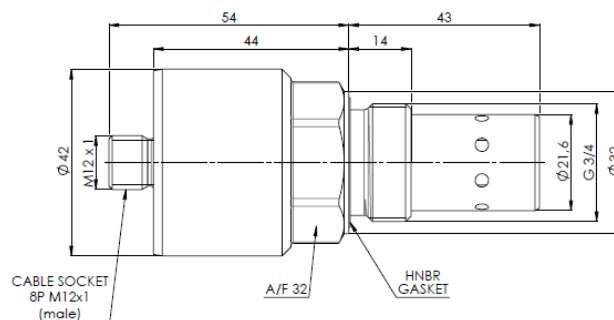

Figure 1: Dimensions drawing for FMSS01S0

4. Mounting

The sensor is designed as a screw-in sensor with a G $\frac{3}{4}$ thread (BSP). Ideally, in hydraulic circuits the sensor is installed in the tank or in the return line. With gear units with forced flushing, the sensor can also be arranged in the purge line. In general, when placing the sensor, the maximum allowable pressures and temperatures are to be considered (see Chapter 3).

Screw the sensor into a prepared position in the tank or in the return line. For installation in the return line also the return line block adapter (Code FMSSA06S0, order number 04.006.00375) can be used. The sealing to the oil side is provided by a profile sealing ring.

To ensure a proper sealing, the sealing surface for inserting the sensor should be specially prepared and the maximum roughness should be $R_{max} = 1.6$. The tightening torque of the sensor is $45 \text{ Nm} \pm 4.5 \text{ Nm}$.

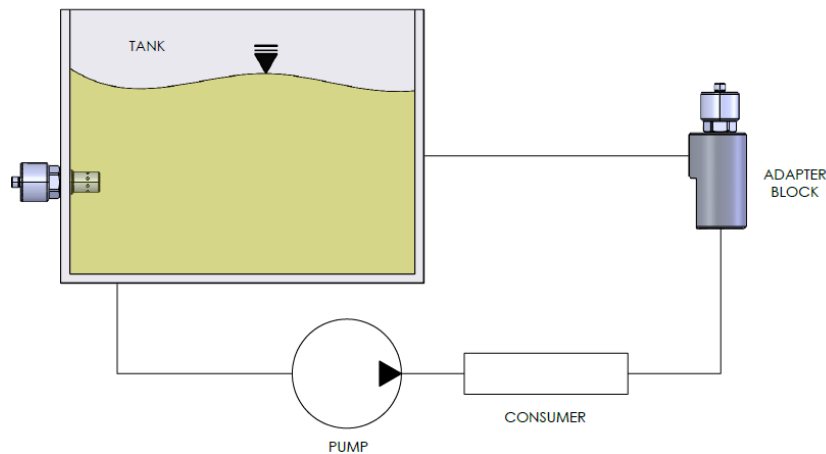

Figure 2: Mounting of a sensor in a oil tank or using the adapter block

To ensure proper operation, please respect the following guidelines and the mounting position and location of the sensor:

- Generally, the measurement should be carried out at a location which is characteristic for the system to be monitored.
- The sensor should be installed at a location at which the medium is sufficiently mixed.
- Ideally, with tank mounting, the sensor should be placed in the vicinity of the return or flushing line.
- Ensure that the sensor is completely covered with oil in all operating conditions of the system. Especially note the pendulum volume of the tank and a possible inclined position. Foaming in the tank should be avoided.
- When installed in the return line or flushing line, it must be ensured that the flushing line is not running empty in any operating situation.
- To avoid thermal influences as far as possible, the sensor should not be installed in the immediate vicinity of hot parts and components (e.g. motor).
- When the oil is insufficiently mixed in the tank, free water may deposit at the bottom. The sensor at position 1 would therefore not detect the free water. In this special case, mounting position 2 is recommended.

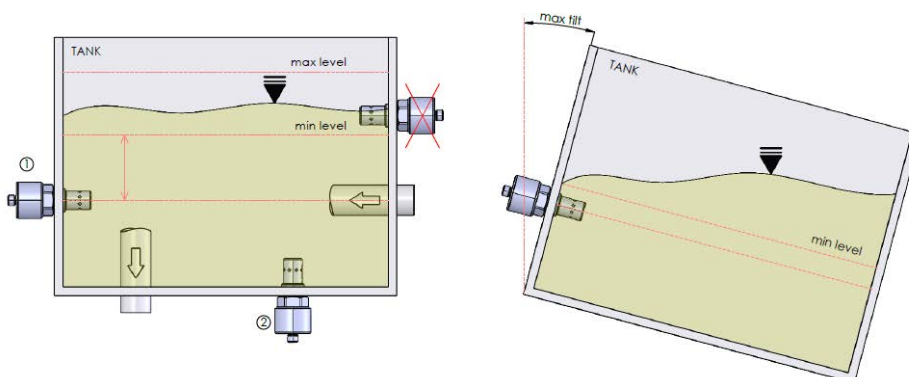

Figure 3: Installation example of correct and incorrect mounting of the sensor in an oil tank

5. Electrical connection

The device must be installed by a qualified electrician. Follow the national and international regulations for the installation of electrical equipment.

Voltage supply according to EN 50178, SELV, PELV, VDE 0100-410 / A1.

For installation, disconnect the device from the power and connect the device as follows:

5.1 Sensor Pin assignment

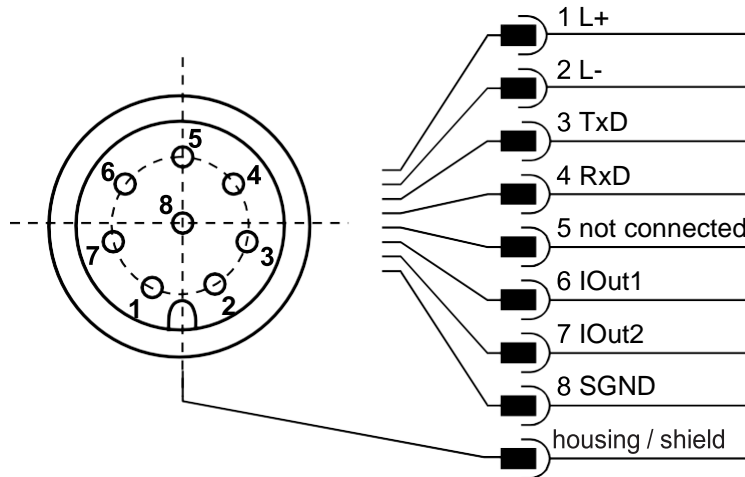

Figure 4: Pin assignment with plan view of the sensor cover

The permissible operating voltage is between 9V and 33V DC. The sensor cable is to be shielded.

In order to achieve the protection class IP67, only suitable plugs and cables may be used.

The tightening torque for the plug is 0.1 Nm.

The default configuration provides the oil temperature on channel 1 (IOut1) and the relative humidity on channel 2 (IOut2). A change in the channel assignment is possible and is described in Chapter 6.2.3 and 6.3

5.2 Analog current outputs (4..20 mA) - measurement without load resistance

The current measurement should be carried out with a suitable ammeter according to the next figure.

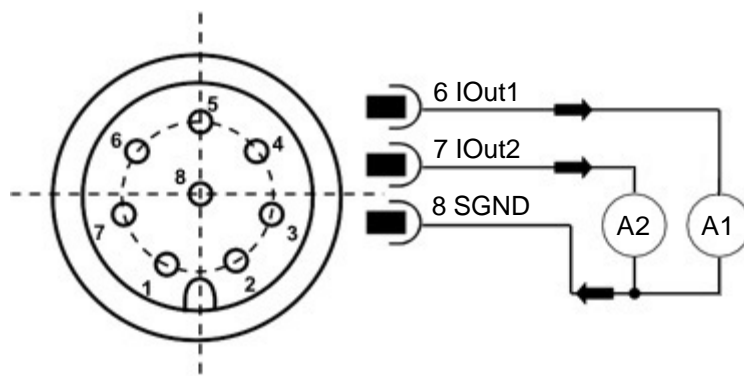

Figure 5: Measurement of the analog outputs 4..20 mA without load resistance

By default, the temperature is displayed at the current outputs in a range between -20 °C and 120 °C and the relative humidity between 0 and 100 %. These limits are fixed and cannot be changed. The scaling of the current output is linear. The assignment of the measured current value to the parameter (humidity and temperature) can be done as follow

| | | | |
|-----------|-----|----|-----|
| IOut [mA] | 4 | 12 | 20 |
| T [°C] | -20 | 50 | 120 |
| RH [%] | 0 | 50 | 100 |

Table 1: Scaling of the analog current outputs

5.3 Analog current outputs (4..20 mA) - measurement with load resistance

In order to measure the currents of both analog current outputs, a load resistance must be connected to each output as shown in Figure 6. The load resistance should be, depending on the supply voltage, between 25 Ohm and 625 Ohm. With the use of a voltmeter, the voltage at each resistor can now be measured.

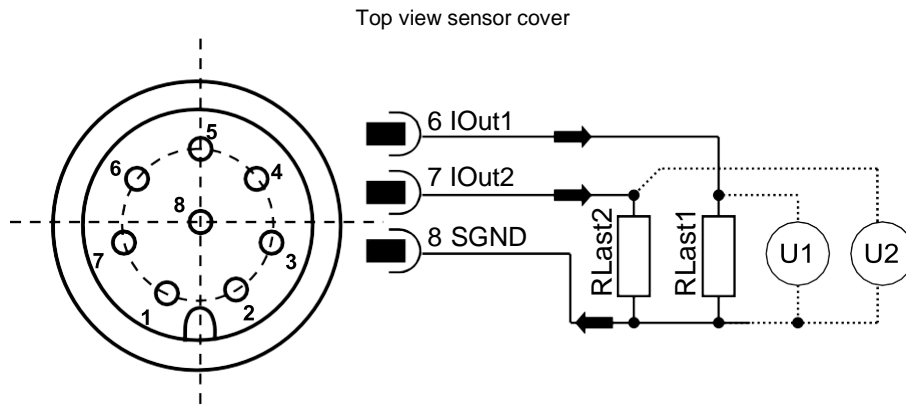

Figure 6: Connection of the load resistances for measuring the analog 4..20 mA outputs

In order to determine the corresponding parameters (humidity and temperature) from the present voltages, the tensions with the formulas from Table 2 must be converted accordingly.

| Output size | Equation | Formula |
|-------------|---|---------|
| T [°C] | $T [^{\circ}C] = \frac{U[V]}{R[W]} \cdot 8750 [^{\circ}C/A] - 55 [^{\circ}C]$ | (5-1) |
| RH in % | $RH[\%] = \frac{U[V]}{R[W]} \cdot 6250 [\%/A] - 25 [\%]$ | (5-2) |

Table 2: Calculation of the output parameters of the analog current outputs measured with load resistance

5.3.1 Load resistance

The load resistance cannot be chosen arbitrarily. It must be adjusted according to the supply voltage of the sensor. The maximum load resistance can be calculated with the formula (5 -3). In Table 3, the load resistances for different voltages are listed.

$$R_{max} [\Omega] = U_{supply} [V] \cdot 25 [\Omega / V] - 200 [\Omega] \quad (5-3)$$

| $R_{max} [\Omega]$ | $U_{supply} [V]$ |
|--------------------|------------------|
| 25 | 9 |
| 100 | 12 |
| 200 | 16 |
| 400 | 24 |
| 625 | 33 |

Table 3: Determination of the load resistance as a function of the supply voltage

6. Communication

6.1 Serial interface (RS232)

The sensor Moisture Sensor FMSS01S0 is provided with a serial interface, via which it can be read and configured. For this purpose, a PC and an appropriate terminal program or a readout software is required (Chapter 6.3).

First, you need to select an existing, free COM port at your computer to which you connect your sensor. An appropriate communication cable for the serial connection between sensor and computer / controller is available under Code FMSA04S0 (order number: 04.006.00191). Alternatively, we also have available a data cable with open ends Code FMSA03S0 (order number: 04.006.00192).

In case the computer should not be provided with a standard COM port, it is possible to use serial interface cards or USB-to-serial converters (Code FMSA05S0, order number: 04.006.00194)

6.1.1 Interface parameters

- Baud rate: 9600
- Data bits: 8
- Parity: none
- Stop bits: 1
- Flow control: none

6.2 Command list

Below, all interface commands for communication with the sensor are listed.

These can be transferred to the sensor by using a terminal program such as e.g. Microsoft Windows Hyper Terminal. By default, this program can be found under Start / Programs / Accessories / Communication (not from Windows 2010 upwards).

6.2.1 Read Command

| # | Instruction format | Meaning | Return format |
|---|--------------------|--------------------------------------|---|
| 1 | RVal[CR] | Reading all measurements | \$RH:xx[%];AH:x[ppm];T:xxx.x[C];PCBT:xxx.x[C]; Time:x.xxx[h];CRC:x[CR][LF] |
| 2 | RID[CR] | Reading the identification | \$FILTREC;FMSS01S0;SN:xxxxxx;SW:x.x.xx; CRC:x[CR][LF] |
| 3 | RCon[CR] | Reading the configuration parameters | \$AO1:x;AO2:x;AHScal:x;CRC:x[CR][LF] |

Table 4: Serial communication: read commands

6.2.2 Write commands

| # | Instruction format | Meaning | Return format |
|---|--------------------|---|---------------|
| 1 | SAO1x[CR] | Assignment of the first current output with a corresponding measured value. Standard: Temperature (see Chapter 6.2.3 and 6.3) | AO1:x[CR][LF] |
| 2 | SAO2x[CR] | Assignment of the second current output with a corresponding measured value. Standard: Relative Humidity (see Chapter 6.2.3 and 6.3) | AO2:x[CR][LF] |
| 3 | CTime[CR] | Deletes the operating hours counter | OK[CR][LF] |

Table 5: Serial communication - write commands

Note:

[CR] = [Carriage Return (0xD)] [LF] = [Linefeed (0xA)]

6.2.3 Setting the analog current outputs

The two analog current outputs are factory-set. On channel 1 the temperature and on channel 2 the relative humidity is issued. However, the sensor makes it possible to change the default output parameters. For this, use the FMSS01S0 Sensor Software (Chapter 6.3) or if you use a terminal program such as e.g. Microsoft Windows Hyper Terminal write the following commands: "SAO1x[CR]" and "SOA2x[CR]" with the corresponding numerical code x.

| Numerical code x | Parameter |
|------------------|------------------------|
| 0 | Temperature (T) |
| 1 | Relative humidity (RH) |
| 100 | Output fixed at 4 mA |
| 101 | Output fixed at 12 mA |
| 102 | Output fixed at 20 mA |

Table 6: Numerical code for the output parameters of the analog current outputs

6.3 FMSS01S0 Sensor Software

If the sensor is connected to a PC and is supplied with power, communication with the sensor is possible by using the FMSS01S0 Sensor Software. This can be downloaded from www.filtrec.com. The software is a C# based program for reading, displaying, storing the data and change the channels (IOut1, IOut2) assignment for FMSS01S0 sensor. The Windows operating systems are supported. The software can be started by double clicking on the file FMSS01S0_Sensor.exe. No other software must be installed. When starting the program, a window with the graphical user interface appears (see Figure 7).

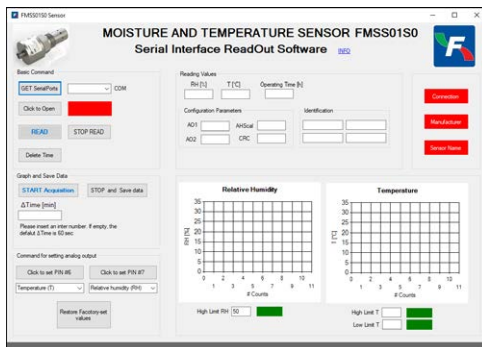

Figure 7: Graphical User Interface

The user interface can be divided into the following 5 sectors:

Sector1: Basic command

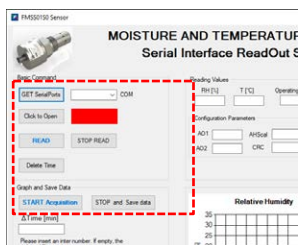

Figure 8: Sector 1 - Basic command

To start the communication process with the sensor, you must select the communication port clicking the button "GET Serial Port" and then select the correct COM with the drop-down menu. Then click the button "Click to Open" to open the selected communication port. The led change color from red to green. If you need to close the communication port, click the button "Click to Close".



Figure 9: Starting the communication

If the communication port is open it is possible to start to read the temperature and relative humidity data, simply clicking the button “READ”. In this case the values of the parameters are displayed on the right side of the user interface, in the Sector 2. These values are updates each 60 second. To stop the reading click “STOP READ”.

Clicking the button “Delete Time” it is possible to reset the operating hours counter of the Sensor. The Operating hours is displayed on the right side of the user interface, in Sector 2.

Sector2: Reading Values

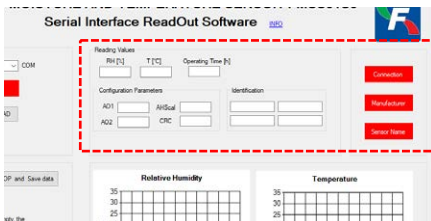

Figure 10: Sector 2 – Reading Values

In this sector are displayed the reading values of relative humidity RH, temperature and operating time obtained when the button “READ” is clicked (see Sector 1). Furthermore, there are shown some configuration parameters and some code of identification of the used sensor. Also these values are visible only after the READ button was clicked.

Sector3: Graph and Save Data

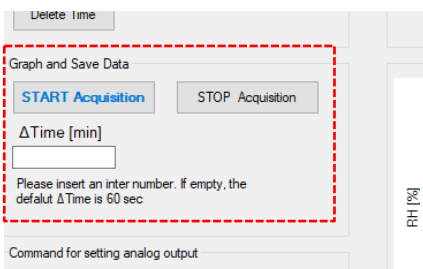

Figure 11: Sector 3 – Graph and Save Data

In this sector there are two buttons. The first “Start Acquisition” enables the acquisition of the relative humidity RH and the temperature updating the values at the frequency specified in the field “ΔTime [min]” or each 60 second if the field “ΔTime [min]” is left empty. When the acquisition starts the result is displayed on the two graphs on the right in the sector 4. After the button “Start Acquisition” was clicked a dialog box appear (Figure 12) for identify the directory where save the data. If you prefer not to select a specific folder, the data will be automatically saved in the default folder set to the 'My Documents' folder on your system. This folder is typically used for storing personal documents and can be accessed easily from various applications. Please note that it is recommended to choose a suitable directory for saving the data to ensure easy access and organization of your files. If the “STOP Acquisition” button is clicked the acquisition of the two parameters is stopped. The data are saved as text files (.txt)

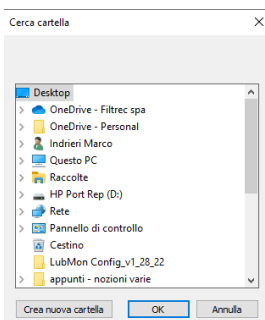

Figure 12: dialog box

Sector 4: Graphs

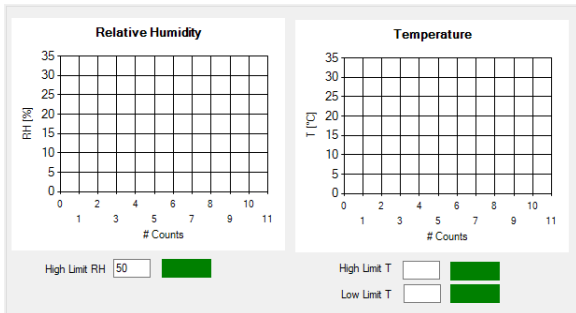

Figure 13: Sector 4 – Graphs

In this sector the graphs display the acquired parameters (see Sector 3). Furthermore, it is possible to set:

- an upper limit for the relative humidity. The default limit value is 50%. When the relative humidity is greater than this value the led change color from green to red, a warning label appears, and a note is written in the saved text file.

- an upper and lower limit for the temperature. If the temperature is higher or lower than these limit the corresponding led change color from green to red, a warning label appears, and a note is written in the saved text file. If these fields are left empty, no limits are applied, and no warning signal appear.

Sector 5: Command for setting analog output

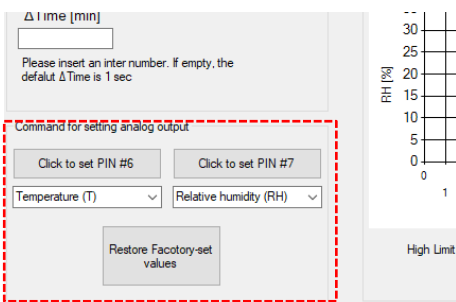

Figure 14: Sector 5 – Command for setting analog output

In this sector it is possible to change the setting of IOOut1 and IOOut2 (see Chapter 5.1). From the drop-down menu it possible to select between Temperature (T), Relative humidity (RH), output fixed at 4 mA, at 12 mA or at 20 mA and clicking on the corresponding button is possible to assign the selected parameter to the selected pin. Clicking the button “Restore Factory-set values” it is possible to reset at the factory assignment, i.e., temperature for the PIN#6 (IOOut1) and relative humidity for PIN#7 (IOOut 2)

Text File:

```

FMSS01S0_data15-06-2023 04.06.35 - Blocco note di Windows
File Modifica Formato Visualizza ?
Filtrec SpA FMSS01S0 SN:510076 SW:5.9.22
Start acquisition: 15-06-2023 04.06.35
End acquisition: 16-06-2023 08.25.41
Warning Humidity: YES, the RH has exceeded the limit value of 50 %
Warning temperature: NO
RH T
[%] [°C]
49 23.2
49 23.1
49 23.2
48 23.1
47 23.2
46 23.2
46 23.2
46 23.4
46 23.3
46 23.4
45 23.4
45 23.3
45 23.2
45 23.3
45 23.5

```

Figure 15: Display of measurement data in the log file

Figure 15 shown an example of the data text file. The text files can be opened with any text editor. In the header there are some general information about the sensor, when started the acquisition and when the acquisition was stopped. Furthermore, there are some notes about the exceeding limits (see sector 4). For graphic representation, the data can be exported in a standard spreadsheet program (e.g. Microsoft Excel).

7. Commissioning

7.1 Function test using a PC

Now have the sensor connected to the power supply by an electrically trained specialist. Connect the sensor via the serial interface (RS232) with a PC and start the FMSS01S0 Sensor Software (see Chapter 6.3). The three LEDs on the right of the software window must change color from red to green when the button "READ" is clicked.

7.2 Function test via the analog current outputs

Have the sensor connected to the power supply by an electrically trained specialist. Now check the analog current outputs (see Chapter 5). The current value should not be under $4 \text{ mA} \pm 0,2 \text{ mA}$ and not over $20 \text{ mA} \pm 0,2 \text{ mA}$. The relation between supply voltage and load resistance must be observed (see Chapter 5.3.1).

8. Reference Values

Generally, in hydraulic system the water can cause damage, therefore everything must be done to ensure that the water content is as low as possible. We recommend to maintaining levels of relative humidity below 50%.

| % r.h. | Measure |
|----------|--|
| 0...50 | No action required |
| 50...100 | Take action to reduce water content. In case of necessity contact the Filtrec service team (info@filtrec.it) |

Table 7: r.h. reference values and countermeasures

9. Maintenance and disposal

From time to time check the sensor. If there are any deposits, carefully clean it by rinsing with fresh oil or isopropyl alcohol. Let the unit dry for a few minutes before mounting.

In case of damage replace the unit. It is not possible to repair the unit. For disposal, please take an environmentally friendly way in accordance with the national regulations.

In case of returns ensure that the unit is free from soiling, especially of dangerous and toxic substances. For transport only use appropriate packaging.

10. Troubleshooting

| Error: No serial communication and analog current outputs < 4mA | |
|---|---|
| <i>Reason</i> | <i>Measure</i> |
| Cable is not properly connected | First, please check the correct electrical connection of the sensor or the data and power cable. Please be aware of the prescribed connection assignment. |
| Operating voltage is outside the prescribed range | Pease operate the sensor in the range between 9 V und 33 V DC. |

| Error: No serial communication | |
|---------------------------------------|--|
| <i>Reason</i> | <i>Measure</i> |
| Wrong communication port selected | Check and correct the choice of the communication port (e.g. COM1) |
| Cable wrong or defective | If possible, use FILTREC data cables |

| Error: Incorrect measurement of the analog current outputs | |
|---|---|
| <i>Reason</i> | <i>Measure</i> |
| A wrong parameter is output | Correct the assignment of the measured values to the current outputs. |

Table 8: Reasons for errors and countermeasures

11. Accessories

| Description | Order Part Number | Code | Drawing |
|---|-------------------|--------------|---|
| <p>Universal power supply</p> <p>Input range: 100...240VAC 50/60Hz Output voltage: 24VDC / max. 0,63A / 15W Temperature range in operation: 0...40°C Compatible with data cable FMSA04S0 Supply line: Euro power cord 2-pole, 1.5m</p> | FMSA01S0 | 04.006.00190 |  |
| <p>Data cable for computer connection</p> <p>Side 1: M12 8-pole, 90° angled, IP67 Side 2: D-Sub connector 9-pole with separate DC Plug for power supply Length: 5m, shielded Temperature range -25°C...90°C Oil-resistant</p> | FMSA04S0 | 04.006.00191 |  |
| <p>Adapter USB - RS232 serial</p> <p>Side 1 (PC): USB A plug Side 2 (periphery): D-Sub connector 9-pole Length: 1.8m</p> | FMSA05S0 | 04.006.00194 |  |
| <p>Data cable with open ends</p> <p>Side 1: M12 8-pole, 90° angled, IP67 Side 2: open Length: 5m, shielded Temperature range -25°C...90°C Oil-resistant</p> | FMSA03S0 | 04.006.00192 |  |
| <p>Sensor connector</p> <p>M12 8-pole, straight, IP67 Suitable for cable diameter 6...8 mm Temperature range -20°C ... 85°C Oil-resistant</p> | FMSA02S0 | 04.006.00193 |  |
| <p>Sensor adapter block for pipe installation</p> <p>Line connectors 3/4" Material: Aluminum Pressure range: up to 50bar Oil-resistant</p> | FMSA06S0 | 04.006.00375 |  |

Table 9: Accessories

Technical information may change without notice



FILTREC S.p.A.
24060 TELGATE (Bergamo) ITALY
Via Dei Morengi, 1 - www.filtrec.com
Tel. +39 035 8368001 - Fax +39 035 831925
E-Mail: info@filtrec.it

MUM02 – REV. 10/23